

MULTIVAP SUPER

Installation guide

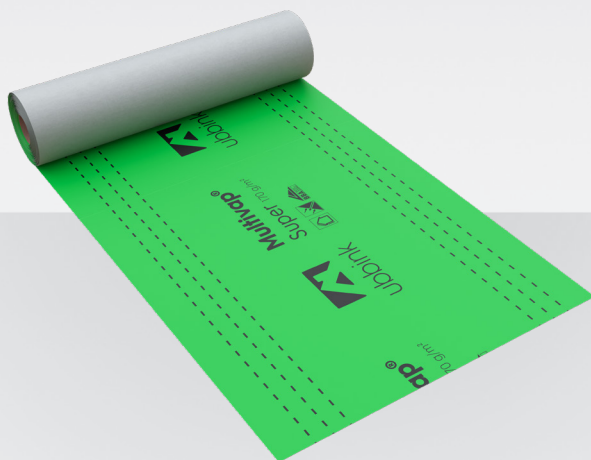

Laying instructions

General Information

When installing the MultiVap Super roofing underlays, the applicable generally recognised rules of technology must always be observed. When selecting the appropriate product and the method of application, the building-physics aspects of the building component must be taken into account. Roofing underlays are not roofing materials for permanent outdoor exposure and should be covered as quickly as possible after installation. If the MultiVap Super underlays are intended to protect the building from precipitation before the final hard roofing is installed (temporary roof function), additional measures are required, such as bonding the overlaps and installing nail sealing tape under the counter battens to prevent water ingress through the fastening points of the counter and supporting battens. This installation guide shows examples. Other designs are possible provided they comply with generally recognized rules of technology. In the event of longer work interruptions or in areas requiring special protection, the roof should always be covered. MultiVap Super roofing underlays are suitable for slate roofing.

1A Installation of MultiVap Super Roofing Underlays

The MultiVap Super roofing underlays are replaced with secured in the area of the vertical and horizontal overlaps or under the counter battens using staple fasteners or wide-head nails. The bonding of the overlaps is carried out using adhesive tapes. MultiVap Super can be installed without deformation at both high and low temperatures. MultiVap Super is laid horizontally with an overlap of approx. 15 cm on the existing wooden boarding/thermal insulation or at right angles to the rafters, free of tension and without sagging. A marking on the roofing underlay indicates the overlap for standard roof pitches. If the standard roof pitch is undershot, the overlap area of the underlay is approx. 20 cm. The roofing underlay is fixed progressively using staples and counter battens. Fastening should be concealed (minimum 10 cm). The printed side is the upper side and faces the installer during installation.

1B Installation Instructions for MultiVap Super with Two Self-Adhesive Strips

For MultiVap Slim ESB 2-SK, the sheets must overlap. Remove the protective films from the adhesive strips and press the upper sheet onto the lower sheet (adhesive to adhesive). Processing temperature: +5 °C to +80 °C.

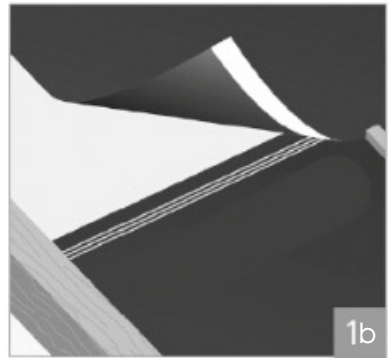
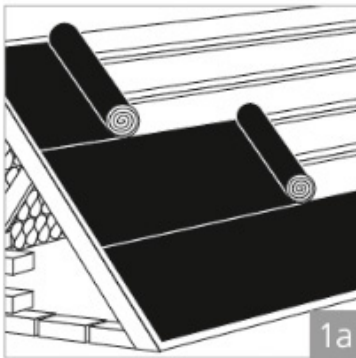

2. Eaves

At the eaves, the MultiVap Super is laid either below the counter battens and eaves board on a drip edge, or above the eaves board on an eaves flashing. Water pockets or a counter-batten slope must be avoided.

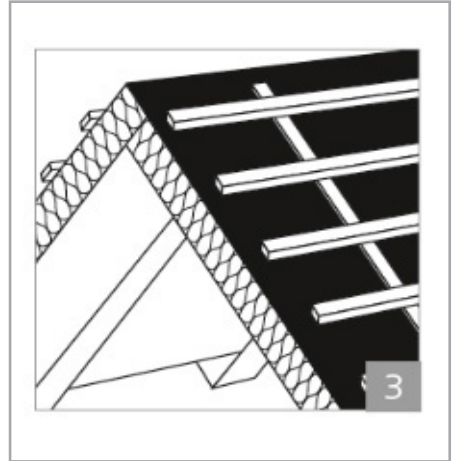
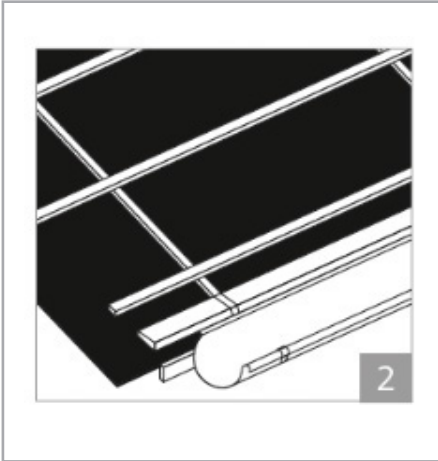

3. Ridge (Non-ventilated Roof Constructions)

At the ridge, MultiVap Super is stretched over the ridge in non-ventilated roof constructions to achieve snow and rain tightness.

4. Ridge (Ventilated Roof Constructions)

In ventilated roof constructions, MultiVap Super ends approx. 50 mm before the ridge apex. The resulting ventilation opening can be bridged above the counter batten with a strip of membrane so that it overlaps the field membranes by at least 15 cm. In non-converted attics where moisture convection cannot be ruled out, sufficient cross-ventilation can be achieved. In such cases, a larger opening in the ridge area or additional openings may be required.

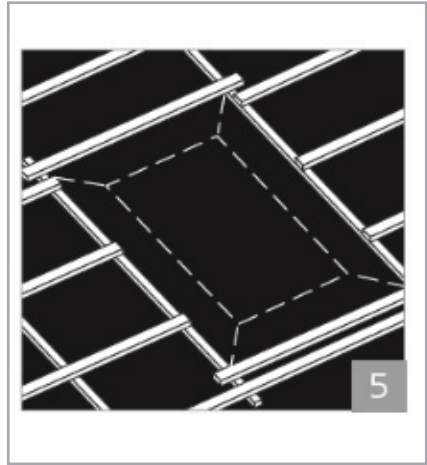
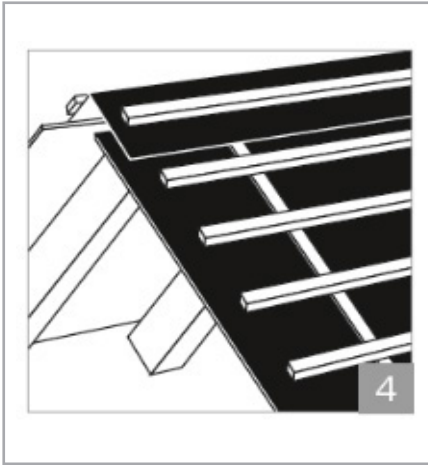

5. **Windows**

When installing roof windows for living spaces, the position of the window must be determined where the upper and lower mounting battens for the window are to be installed. Remove the counter battens in the area of the required drainage channel and cut into the MultiVap Super. Build up the counter battens in the window area between the supporting battens using pieces of batten, fold back the resulting membrane strips onto these and fasten them.

Note:

During installation, the current technical rules of the BBA and the installation guidelines must be observed. No liability is accepted in the event of improper installation.

Description	Standard	Unit	Value	Tolerance
Fire behavior	EN 13859-1:2010	Class	E	- -
Resistance to water penetration		Class	W1	- -
Resistance to water penetration after artificial ageing		Class	W1	- -
SD value		m	0.03	-0.02 / +0.05
Tensile strength I/q		N/50 mm	360 / 220	-40 / -30 +40 / +30
Tensile strength after artificial ageing I/q		N/50 mm	250 / 155	-40 / -30 +40 / +30
Elongation I/q		%	80 / 90	-30 / -30 +30 / +30
Elongation after artificial ageing I/q		%	60 / 70	-30 / -30 +30 / +30
Resistance to nail tearing I/q		N	230 / 230	-20 / -20 +20 / +20
Service temperature range		°C	-30 / +80	- -



ENERGY



VENTILATION



BUILDING

Nederland • 📞 +31 313 480-300 • @ productadvieslijn@ubbink.nl

France • 📞 +33 (0)2 51 13 46 46 • @ ubbink@ubbink.fr

Belgium • 📞 +32 9 237 11 00 • @ info.bouw@ubbink.be

United Kingdom • 📞 +44 1604 433-000 • @ info@ubbink.co.uk

Deutschland • 📞 +49 2301 91011-0 • @ info@ubbink.de

Italia • 📞 +39 045 602 0433 • @ info@ubbink.it



Ubbink UK

@ info@ubbink.co.uk • 🌐 www.ubbink.com