

Aerfoam 160 Bend 90°

Article number: 188225

Product overview

The Aerfoam 160 mm 90° bend allows directional changes within the Aerfoam system. Made of expanded polyethylene (EPE) duct, it minimises the risk of condensation and energy loss. It is very light and extremely easy and safe to install. All Aerfoam parts connect to each other using strong, airtight mechanical connections. They can also be securely mounted to walls or ceilings using brackets. Aerfoam is ideal for both central mechanical ventilation and domestic hot water heat pump systems.

- Insulated to minimise the risk of condensation and energy loss.
- Easy mechanical connection and mounting.
- Lightweight and easy to cut, ensuring quick installation.
- Impact resistant.

Product dimensions

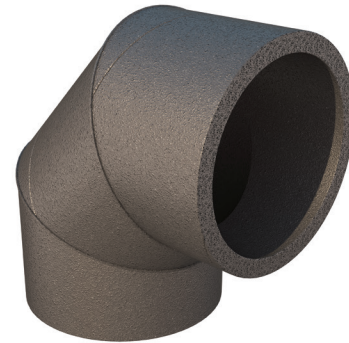
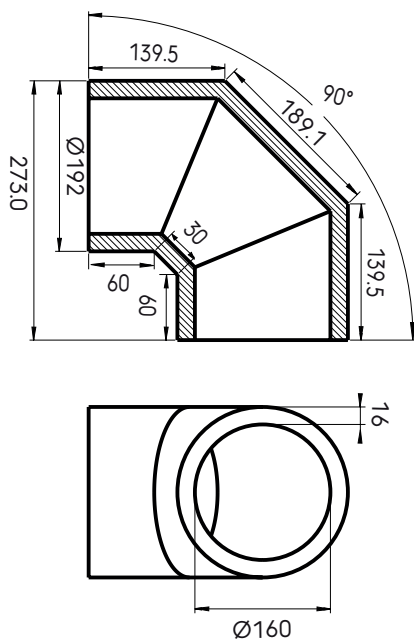

Aerfoam 160 Bend 90°

Article number: 188225

Technical specifications

Technical	
Colour	Grey
Insulated	<input checked="" type="checkbox"/>
Diameter inner	160 mm
Diameter outer	192 mm
Insulation thickness	16 mm
Performance	
Insulation performance	0.041 W/m.K
Temperature resistance (min.)	-30 °C
Temperature resistance (max.)	60 °C
Installation temperature (min.)	-30 °C
Installation temperature (max.)	60 °C
Zeta supply 1 connection	0.85
Zeta extract 1 connection	0.85
Dimensions	
Length gross	273 mm
Width	191 mm
Height	273 mm
Net weight	0.06 kg

Aerfoam 160 Bend 90°

Article number: 188225

Technical details

DN160 90° Bend		
Zeta [-]	0,85	
Qv [m³/h]	Δp [Pa]	V [m/s]
50	0,24	0,69
100	0,97	1,38
150	2,19	2,07
200	3,89	2,76
250	6,08	3,45
300	8,76	4,14
350	11,92	4,84
400	15,57	5,53
450	19,71	6,22
500	24,34	6,91
550	29,45	7,6