

Air Excellent DBOX 206 Inline Adaptor Kit DN125

Article number: 188636

Product introduction

An Air Excellent distribution box accessory used to convert the DBOX 206V into a DBOX 206H.

- Modular manifolds, which can be used with all 6 duct types
- Semi-rigid plastic ducts on a roll and airtight mechanical connections, which are extremely easy to install
- Low system pressure loss due to radial design
- Airtight (class D/ATC 2 up +/- 2000 Pa) thanks to mechanical connections, which minimises fan energy use and sound production
- TÜV SÜD and ISEGA tested and certified, REACH compliant

Product dimensions

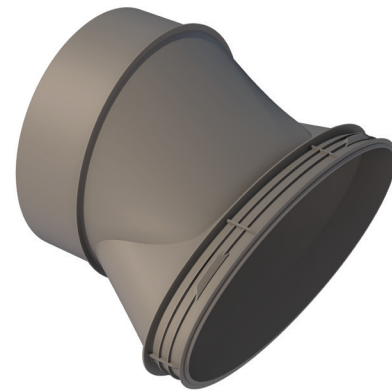
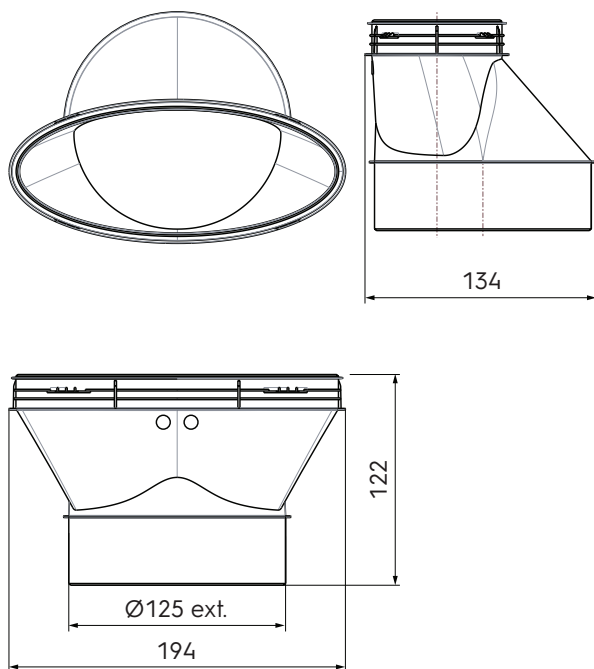

Performance

Airtightness Class D for Air Excellent ductwork, Air Excellent ductwork accessories and the Air Excellent plastic distribution boxes. Tested according to TÜV SÜD Standard TAK 01-2013 (system pressure: + 2000 Pa/- 2000 Pa)

Air Excellent DBOX 206 Inline Adaptor Kit DN125

Article number: 188636

Technical specifications

| Specifications | |
|-------------------------------|-------------------------------------|
| Technical | |
| Colour | Grey |
| Material | PP |
| Anti static | <input checked="" type="checkbox"/> |
| Antimicrobial | <input checked="" type="checkbox"/> |
| Performance | |
| Temperature resistance (min.) | -20 °C |
| Temperature resistance (max.) | 60 °C |
| Reaction to fire: Euro class | E |
| Dimensions | |
| Length gross | 122 mm |
| Width | 194 mm |
| Height | 134 mm |
| Net weight | 0.19 kg |