

Air Excellent DBOX Stepped Adaptor 125-150-160-180

Article number: 188565

Product introduction

An Air Excellent distribution box accessory used to connect mass flow ductwork to Air Excellent distribution boxes.

- Modular manifolds, which can be used with all 6 duct types
- Semi-rigid plastic ducts on a roll and airtight mechanical connections, which are extremely easy to install
- Low system pressure loss due to radial design
- Airtight (class D/ATC 2 up +/- 2000 Pa) thanks to mechanical connections, which minimises fan energy use and sound production
- TÜV SÜD and ISEGA tested and certified, REACH compliant

Product dimensions

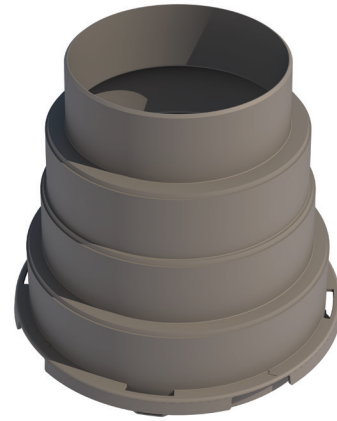
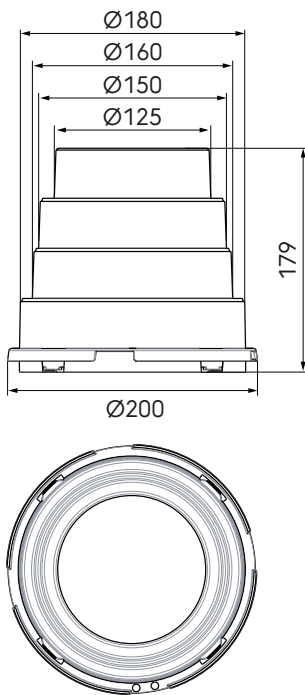

Technical specifications

Specifications	
Technical	
Colour	Grey
Material	PP
Anti static	<input checked="" type="checkbox"/>

Air Excellent DBOX Stepped Adaptor 125-150-160-180



Article number: 188565

Technical specifications (continuation)

Technical	
Antimicrobial	<input checked="" type="checkbox"/>
Performance	
Temperature resistance (min.)	-20 °C
Temperature resistance (max.)	60 °C
Reaction to fire: Euro class	E
Dimensions	
Length gross	200 mm
Width	200 mm
Height	179 mm
Net weight	0.2 kg