

Air Excellent DBOX 800 Series Acoustic Insulation

Article number: 188039

Product introduction

Acoustic insulation for Air Excellent 800 series distribution boxes only.

- Modular manifolds, which can be used with all 6 duct types
- Semi-rigid plastic ducts on a roll and airtight mechanical connections, which are extremely easy to install
- Low system pressure loss due to radial design
- Airtight (class D/ATC 2 up +/- 2000 Pa) thanks to mechanical connections, which minimises fan energy use and sound production

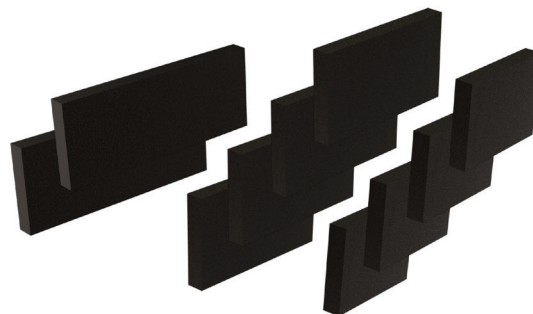

Product dimensions

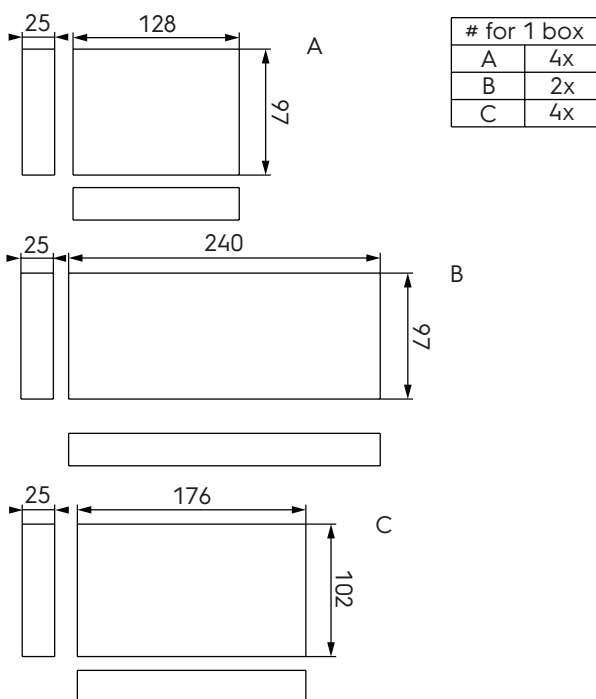

Technical specifications

Specifications	
Technical	
Colour	Black
Material	Foam
Dimensions	
Net weight	0.08 kg