

UB17 SLATE SPACE VENT

Installation instructions



ubbink

Build smart.

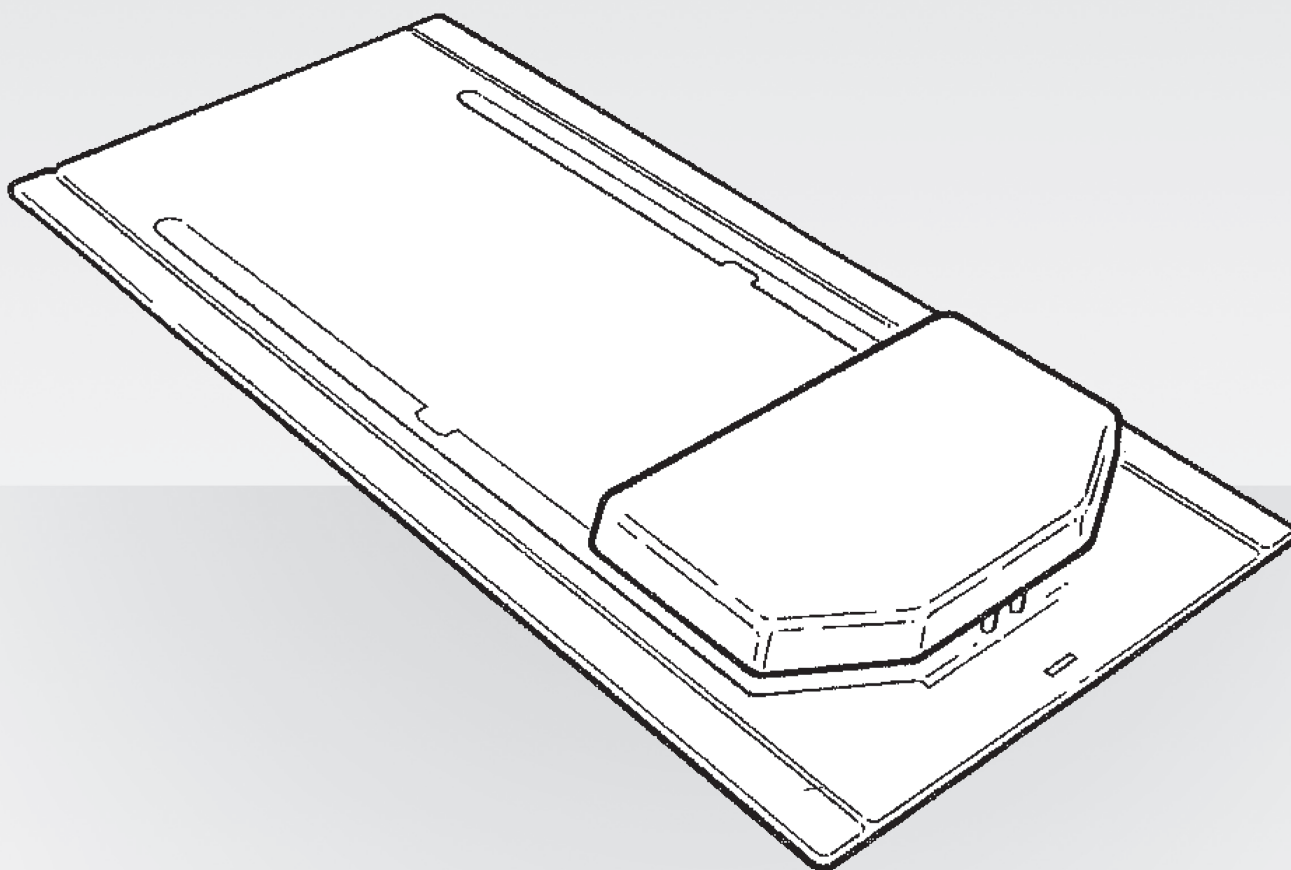

UB17 Slate Space Vent

Key Marketing Points

- **Universal base**
- **Large free vent area**
- **Made from Polyethylene**
- **Easy to install with minimal slate cutting**
- **Aesthetically pleasing**
- **Terminal adaptor available**

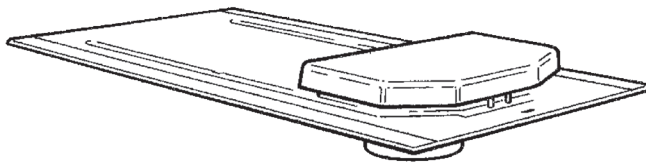
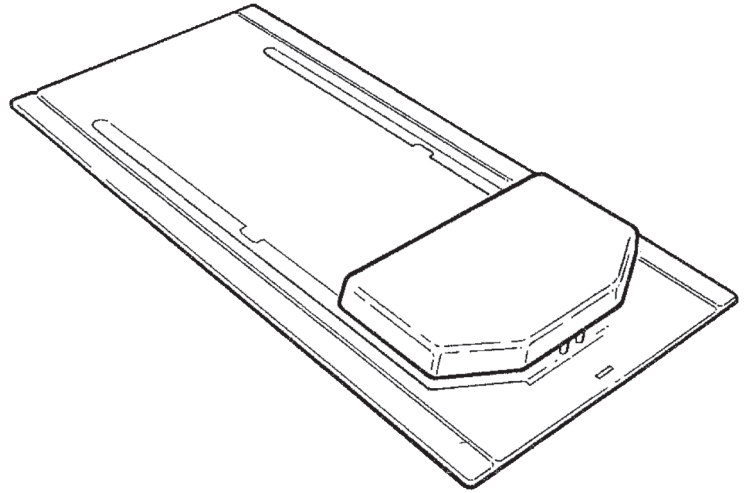

Roof void ventilation slate with free vent area of 10,000mm²

The base as supplied is a direct replaced for a 600 x 300 slate.

Where 500 x 250 slates are being used the moulded 25mm wide side bands are trimmed off and the inner set of fixing points used.

Minimal slate cutting involved in the installation. Manufactured in black UV stabilised plastic.

Suitable for high and low level ventilation.

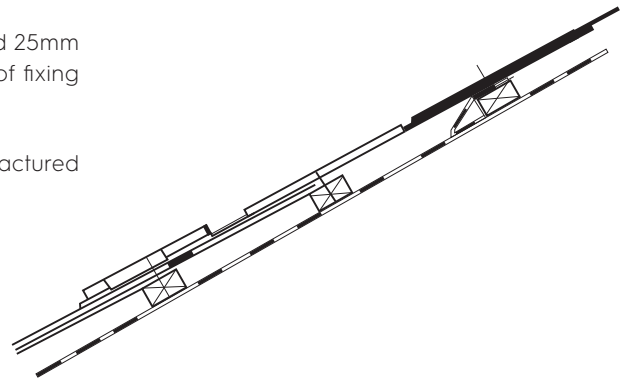

Fixing Instruction

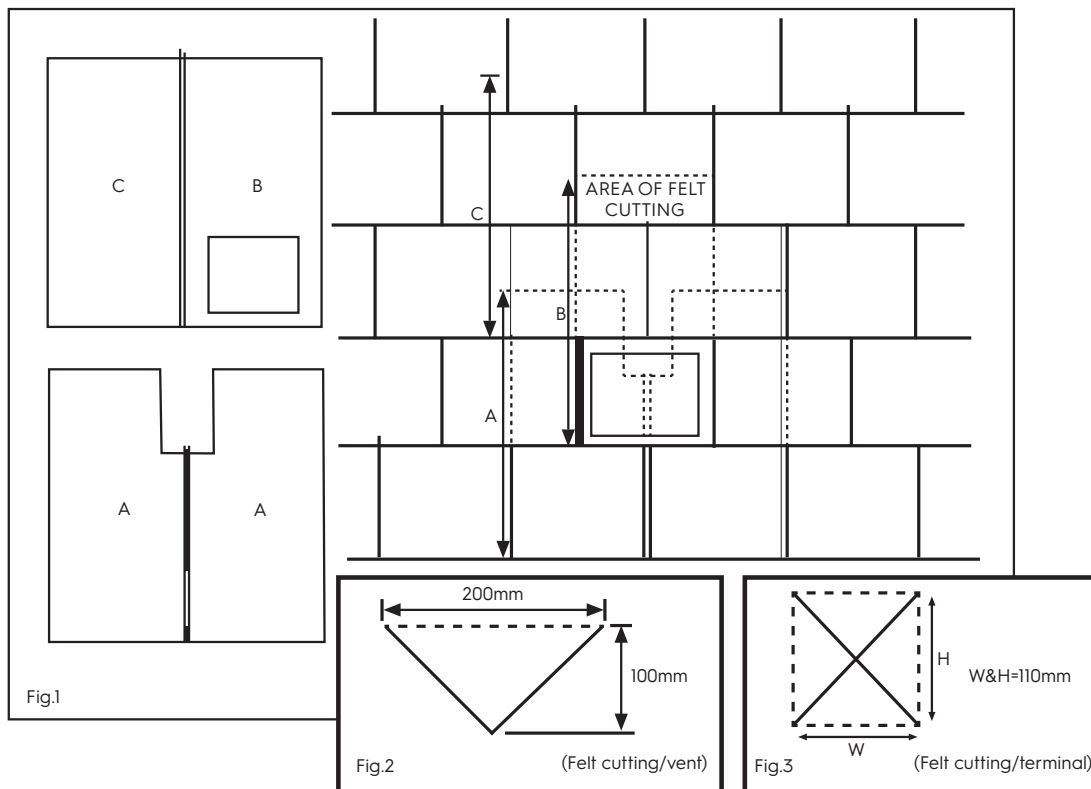

New Build

1) Slating and Preparation

Complete slating to the point where the SlateVent is to be located. For 500 x 250 installation – trim SlateVent to size using guide lines.

2) Cutting of Felt/Sarking/Boarding

- Cut sarking felt in the shape of a 'V' (figure 2) immediately below the batten keeping it above the hole in the underside of the vent.
- Fold the felt flap over the batten at the top of the hole and tack in position.

With rigid sarking or boarding, a hole must now be cut to the size of the aperture through the felt to allow air to reach the roof void.

3) Cutting of Slates

Two slates to be cut at top corner (one left and one right) in row A.

600 x 300 cut 225 x 65mm

500 x 250 cut 170 x 65mm

4) Positioning of SlateVent

Place SlateVent in position and fix using slate manufacturers fixing or with roofing nails to the batten through the fixing points at the sides of the unit. Fix copper roofing nail through the predrilled hole in the centre bottom on the skirt.

5) Complete Slating and Dressing Over SlateVent

Complete slating in the normal way.

Existing Build

1) Preparation

Remove one slate in row B where vent is to be positioned and two slates in row C. Cut exposed slates in row A as at 3.

2) Cutting of Felt/Sarking/Boarding

As 2 (a) & (b).

3) Positioning Unit

As 4.

4) Complete of Reslating and Dressing Over SlateVent

Replace two slates in row C.

Where regular fixing points cannot be used – slate straps should be fixed and copper nails replaced as necessary.

Conversion – U17 Vent to Terminal

▲ NB. Adaptor must be fitted before installation.

To convert a UB17 vent to a terminal- push fit adaptor (no. 294390) to underside of vent. Install by trimming and fixing slates as above. Cut felt/boarding with X cut, as Figure 3 to allow for penetrations of pipe & ensure tabs are pulled upwards. In some instances, it may be necessary to trim the batten.



ENERGY



VENTILATION



BUILDING

Nederland • 📞 +31 313 480-300 • @ productadvieslijn@ubbink.nl

France • 📞 +33 (0)2 51 13 46 46 • @ ubbink@ubbink.fr

Belgium • 📞 +32 9 237 11 00 • @ info.bouw@ubbink.be

United Kingdom • 📞 +44 1604 433-000 • @ info@ubbink.co.uk

Deutschland • 📞 +49 2301 91011-0 • @ info@ubbink.de

Italia • 📞 +39 045 602 0433 • @ info@ubbink.it



Ubbink International

@ info@ubbink.com • 🌐 www.ubbink.com

Copyright © 2023 Ubbink | Content is subject to change without notice, no liability for errors and misprints
Availability and configurations may differ per country | UB-2023-10-V01

100000072259