

# Air Excellent DB206 horizontal adaptor 160

Article number: 188977

## Product introduction

The horizontal adaptor facilitates easy connection of the 160mm Aerfoam insulated ducts to an Air Excellent distribution box.

- Minimizes system pressure loss with its efficient design
- Ensures airtight and safe assembly with integrated TPE seals, reducing fan energy use and minimizing sound production
- Suitable for new build and renovation
- Easy maintenance and servicing
- Easy to install, tool-free installation, lightweight material.

## Product dimensions

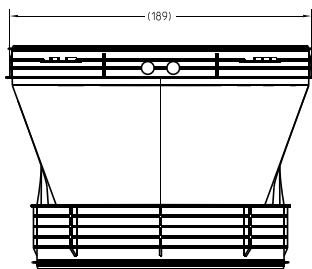
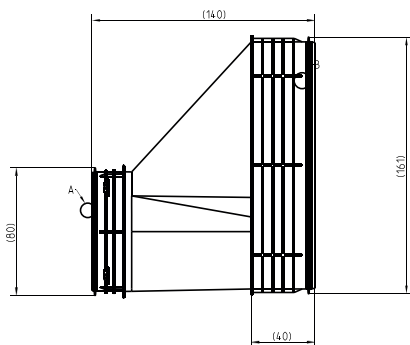

## Technical specifications

Technical	
Colour	Grey
Anti static	<input checked="" type="checkbox"/>
Antimicrobial	<input checked="" type="checkbox"/>
Diameter inner	160 mm
Performance	
Temperature resistance (min.)	-20 °C

# Air Excellent DB206 horizontal adaptor 160

Article number: 188977

## Technical specifications (continuation)

Performance	
Temperature resistance (max.)	60 °C
Reaction to fire: Euro class	E
Dimensions	
Length gross	140 mm
Width	189 mm
Height	161 mm
Net weight	0.237 kg